

# USER MANUAL

Published October 2015  
Software Version TRX-916



ZAXCOM.COM

## TRXLT2

When Size Matters

**KNOWING YOUR TRXLT2..... 4**

**HOME SCREEN EXPLAINED ..... 6**

**MAIN MENU..... 7**

- NAVIGATING THE MAIN MENU .....7
- EXITING THE MAIN MENU.....7
- MICROPHONE GAIN SET .....7
- UHF TRANSMIT FREQUENCY SET.....7
- PLAYBACK CONTROL.....7
- TIME CODE FRAME RATE SET.....8
- TIME LEFT ON CARD.....8
- TRANSMITTER LOCK PAGE .....8

**EXTENDED MENU..... 9**

- ENTERING AND NAVIGATING THE EXTENDED MENU .....9
- EXITING THE EXTENDED MENU.....9
- HIGH PASS FILTER.....9
- 2K NOTCH FILTER ENABLE.....9
- UHF TRANSMIT FORMAT.....9
- IFB ENABLE .....10
- IFB VOTING ENABLE .....10
- IFB MODE .....11
- ZAXNET RECEIVE FREQUENCY SET.....11
- ZAXNET TRANSMIT FREQUENCY SET.....12
- IFB RECEIVE PULSE SET .....12
- IFB RECORD BEEP .....12
- POWER-UP MODE.....13
- SD CARD FORMAT .....13
- TC JAM MODE SELECT .....14
- TIME CODE SOURCE SELECT.....14
- MUTE TIME CODE TRANSMISSION UNTIL JAMMED .....14
- IFB JAM THRESHOLD.....14
- GROUP ID SET .....15
- UNIT ID SET .....15
- DYNAMICS .....16
- BATTERY TYPE SET .....17
- RECORDING MODE SET.....17
- BOOT UP POWER MODE SELECT .....17
- ALLOW IFB REMOTE CONTROL .....17
- QRX SOFTWARE UPDATE.....18
- TRANSMITTER DISABLE - RECORD ONLY MODE.....18
- LOW BATTERY STOP SET .....18
- AUTOMATIC RECORD AFTER BOOT UP.....19
- TRANSMITTER NAME SET .....19
- HIDE ENCRYPTION MENU.....19
- ENCRYPTION CODE SET.....20

**MEDIA.....21**

- MEDIA CAPACITY.....21
- RECORDING FORMAT .....21

**FIRMWARE .....22**  
  UPDATING TRX FIRMWARE .....22  
  UPDATING AN ERX WITH A TRX TRANSMITTER .....23

**INPUTTING AUDIO .....24**

**RECOMMENDED MICROPHONES .....24**

**WIRING DIAGRAMS.....24**  
  TWO WIRE MICROPHONE CONFIGURATION.....24  
  THREE WIRE MICROPHONE CONFIGURATION .....24  
  STEREO MICROPHONE CONFIGURATION – FOR TRXLT2S.....25  
  BALANCED LINE LEVEL AND TIME CODE INPUT .....25  
  STEREO LINE LEVEL .....25

**OPERATING FREQUENCIES.....26**  
  ZAXNET REMOTE CONTROL AND TIME CODE .....26  
  UHF AUDIO .....26

**PRODUCT SUPPORT .....28**

**SPECIFICATIONS.....29**

**ZAXCOM WARRANTY POLICY AND LIMITATIONS.....30**

## Knowing your TRXLT2



1. SSMA Antenna Connector
2. LCD Display
3. Card Key
4. Microphone Input Connector (3 Pin Lemo)
5. INC / Record Key
  - Increases the parameters of a menu item.
  - When in the Home Screen pressing INC with the CARD key will put the TRX into record.
  - When in the Transport Control Screen while not recording will cause the TRX to play back.
  - Press it while playing back to fast forward.
  - Press and hold while in the Transport Control Screen to advance to the next segment.
  - Press it in the Home Screen to display the current segment number.
6. DEC / Stop Key
  - Decreases the parameters of the menu items.
  - When in the Home Screen pressing DEC with the CARD key will stop the recording.
  - When playing back from the Transport Control Screen will cause the TRX to stop.
  - Press and hold while in the Transport Control Screen will jump back to the previous segment.
  - Holding it while playing back will take you to the start of that segment.
  - Pressing it in the Home Screen will display the battery voltage.
  - Pressing it three times quickly while in the home screen will advance you to the extended menu.
7. Menu / Play Key
  - Press it to access the next menu.
  - Pressing it while powering up will take you into the extended menu.
  - Press it with the CARD key to playback a segment.

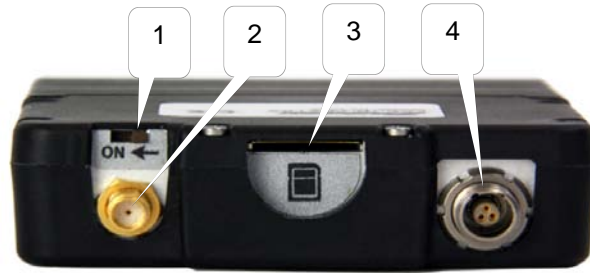

1. Power Switch
2. SSMA Antenna Connection
3. Media Slot Media Slot

To insert a Micro SD card, with the screen of the transmitter facing you, turn the card so the finger contacts are facing you and pointing down toward the slot. Insert the card into the slot and press it down until you here a slight click. To remove it, press the card in until you hear the same click again.

4. Microphone / Input connector (3 pin Lemo)

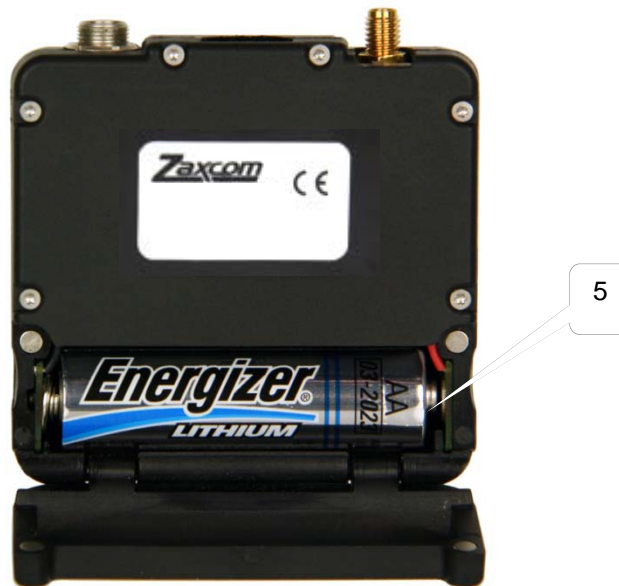

5. Battery Compartment

TRXLT2 will use 1 AA battery. Alkaline, Lithium or NiMH batteries can be used.

## Home Screen Explained

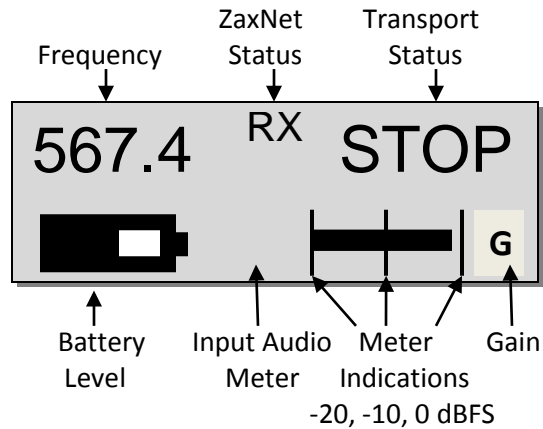

### Frequency

This is the transmit frequency of the TRXLT2.

If the TRXLT2 is being used in RECORD ONLY mode "NOTX" will be displayed.

### ZaxNet Status

- RX - The TRXLT2 is set to receive ZaxNet time code and commands.
- TX - The TRXLT2 is sending ZaxNet time code and audio.

**Transport Status** - Displays the current mode of the recording feature.

- STOP – Recording / Playback is stopped
- LREC – TRX is recording and LOOP RECORD mode is enabled
- REC – TRX is recording and NON-LOOP RECORD mode is enabled
- WAIT – May appear just before going into record, or if the card is ejected while recording.

**Input Audio Meter**- Displays the modulation of the inputted audio signal.

If using a stereo transmitter and it is being in stereo mode both the left and right audio levels.

**Gain** - "G" Appears when the transmitter is receiving change of gain commands via ZaxNet.

**When in the home screen:**

- Press and hold the INC key to display the number of record segments are on the card. Note that regardless of the size of the card it is limited to 256 segments.
- Press and hold the DEC key to display the current battery voltage
- Pressing the DEC key three times quickly will take you to the extended menu.

## Main Menu

### Navigating the Main Menu

- Press the MENU key to enter the menu.
- To advance to the next menu press the MENU key again.

### Exiting the Main Menu

- To exit the menu at any time press and hold the MENU key for 1.5 seconds

### Microphone Gain Set

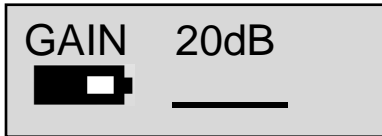

The microphone gain is adjusted from this menu. This menu displays the gain setting in decibels and a meter indicates the audio signal. The meter is displayed horizontally from left to right. In the case of a TRXLT2S operating in stereo mode, two meters will be displayed - one for each channel. Please note that the gain in stereo mode is applied to both sources.

### UHF Transmit Frequency Set

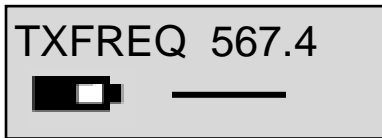

This menu is where the UHF transmit frequency is set.

- Short presses of the INC or DEC key causes the value to change by 0.1 MHz
- Holding the INC or DEC key causes the value to change by 0.5 MHz

### Playback Control

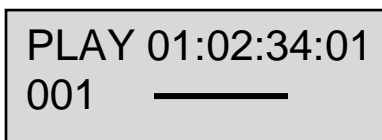

Recorded files can be played back from this page.

The top line displays the current mode of the recorder: REC, PLAY or STOP followed by the time code.

The bottom line contains the current segment number and the audio level.

#### Playing back from the transport page:

- Pressing the INC key while stopped will play the segment that is displayed.
- Pressing the INC key while in play mode will fast forward.
- Pressing the DEC key while playing back will stop the playback.
- Holding the DEC key while playing back will take you to the start of that segment.
- Pressing the DEC key while stopped will take you back.

## Time Code Frame Rate Set

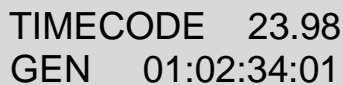

TIMECODE 23.98  
GEN 01:02:34:01

This menu is where the time code frame rate is set.

The TRXLT2 will lock to and record all standard time code frame rates.

- 23.98, 24, 25, 29.97DF, 29.97DF, 30 DF, 30 NDF

## Time Left on Card



TIME LEFT 20H  
TIME USED 4H

This page displays the remaining record time left on the card and the time already recorded on the card.

Please note that this page will not be displayed if the card was not inserted prior to boot up.

## Transmitter Lock Page

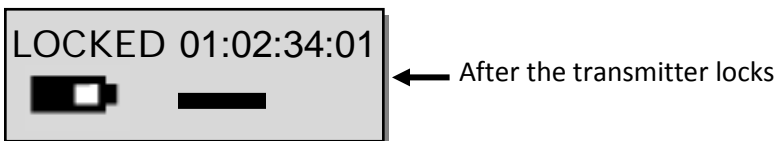
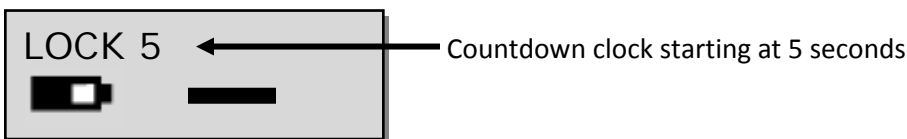

This page enables a lock function to prevent any accidental key presses.

When you land on this page a countdown clock will begin. After 5 seconds the transmitter will lock and the display will indicate that it is LOCKED followed by the time code.

If you exit this screen before the 5 seconds is up the transmitter will not lock.

### To unlock the transmitter

- Simultaneously press the MENU and INC keys.  
Or
- Powering down the unit will clear the lock.



## Extended Menu

### Entering and Navigating the Extended Menu

- Press and hold the MENU key while powering up the unit.
- Pressing the MENU key will advance you to the next menu item.

### Exiting the Extended Menu

- Hold down the MENU key to get back to the extended menu home page then press the INC key.  
Or
- Cycle the power

### High Pass Filter

HIGH PASS: OFF

The high pass filter is turned on and adjusted from this menu.  
The high pass filter range is 70Hz to 220Hz in 10Hz increments.

### 2K Notch Filter Enable

2K NOTCH FILTER  
OFF

The 2 Kilohertz notch filter is turned on or off from this menu.  
The 2K notch filter is useful in removing digital RF interference that can potentially be introduced into the microphone.

### UHF Transmit Format

TX FORMAT:  
XR MONO

The UHF transmission format is selected from this page.

Please note if the transmission format that is set here, and the format set on the receiver do not match, the receiver will be unable to decode the audio from the transmitter. Please note that after any changes to the transmit format the TRXLT2 will be required to be rebooted before the new setting takes effect.

- **XR (MONO)** -This format uses enhanced modulation for better range and less dropouts - and is the recommended setting.  
XR will be used with the NORMAL setting on the QRX and is not compatible with the RX900.
- **US MONO** - This format is used for mono transmission.  
US MONO will be used with the NORMAL setting on the QRX and the 0=US setting on the RX900 receiver.
- **STEREO** -This format is used for stereo transmission of a TRXLAS2  
Stereo will be used with the NORMAL setting on the QRX and 2=ST setting on the RX900 receiver.
- **EUROPEAN** -This format is for use in countries where a normal width channel is NOT legal.  
European will be used with the NARROW setting on the QRX and 1=EU setting on the RX900 receiver.
- **US MONO-R** -Similar to **US MONO**. This can be used to force mono audio to the right channel.

## IFB Enable

IFB MODE: TX

This menu sets the mode of the ZaxNet transceiver.

- **OFF** - The ZaxNet transceiver is disabled. The TRX will not receive ZaxNet commands or time code and it will not send any ZaxNet audio. If this is set to OFF the next 5 ZaxNet menu items will not appear.
- **RX**- The ZaxNet transceiver will receive ZaxNet commands and time code.
- **TX**- The ZaxNet transceiver will send ZaxNet confidence audio and time code.

Please note if IFB RX TO TX is set to anything other than Normal you will not be allowed to set the IFB mode to off.

## IFB Voting Enable

*This menu will not appear if the IFB settings allow the TRX to go into transmit mode.*

IFB VOTING  
NORMAL (OFF)

The IFB mode menu is where the IFB Voting function is enabled / disabled from.

The purpose of IFB voting is to allow the ZaxNet receiver to choose, and switch to, the stronger signal from two different ZaxNet transmitters. One purpose of this is if you are on a large set you can place a second IFB transmitter at a different location and the ZaxNet receiver will choose the stronger signal.

Please note that you need to set the second ZaxNet transmitting frequency to exactly 2MHz higher than the first ZaxNet transmitter.

Please note that the IFB voting is only available if ZaxNet in the TRXLT2 will never go into transmit mode. So the IFB RX to TX mode (next menu item) needs to be set to normal RX, and IFB mode (previous menu item) is not set to off.

### IFB Mode

- IFB RX TO TX:  
OFF (NORMAL RX)

← Receive only mode.  
The ZaxNet transceiver will only receive ZaxNet and NOT go into transmit mode. Therefore no ZaxNet TC and/or audio will be transmitted. This shuts off the ZaxNet transmitter.
- IFB RX TO TX:  
0 SECS: TX ONLY

← Transmit only mode.  
The ZaxNet transceiver will only transmit ZaxNet TC and audio and will NOT receive wireless TC or ZaxNet commands.
- IFB RX TO TX:  
20 SECS

← Receive then Transmit mode.  
After boot up the ZaxNet transceiver will search for a ZaxNet signal for the selected time so it can receive and lock time code before it begins to transmit TC and confidence audio.

This menu adjusts the mode of the ZaxNet IFB transceiver and how long after power up it will search for ZaxNet time code before it begins transmitting IFB audio for monitoring purposes. This is necessary if you want your transmitter to lock to ZaxNet time code before you use your ZaxNet transmitter to send confidence audio.

Please note that after changing the IFB mode the transmitter must be power cycled for the setting to change.

### ZaxNet Receive Frequency Set

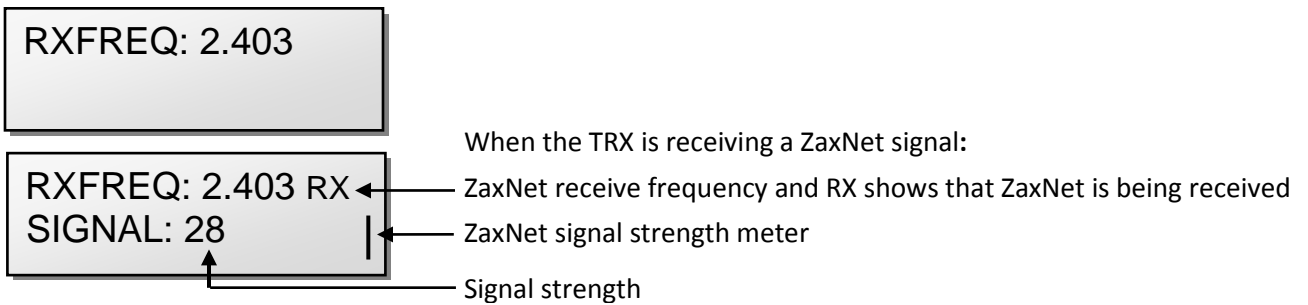

This menu is where the ZaxNet receive frequency is set.

The ZaxNet receive frequency is the frequency that the ZaxNet receiver will get its wireless time code and remote control commands on. This frequency will need to match the frequency of the corresponding ZaxNet transmitter. The ZaxNet transmitter can be a QRX with QIFB, Nomad, TRX900CL or IFB100/200. The TRX can also receive ZaxNet time code from another TRX transmitter or a ZFR recorder that is transmitting ZaxNet on this frequency.

## ZaxNet Transmit Frequency Set

IFB TX FREQ:  
2.420

This menu is where the ZaxNet transmit frequency is set.

The ZaxNet transmit frequency is the frequency that the ZaxNet transmitter will broadcast time code and audio on for the purpose of confidence audio monitoring via an ERX receiver or Nomad. Please note this transmitted audio is for quality control purposes and the expected range will be less than 20 feet.

Please note this transmitted audio is for quality control purposes and the expected range will be less than 20 feet.

## IFB Receive Pulse Set

*This menu will only appear if IFB is set to go into transmit mode.*

IFB RX PULSE:  
NEVER

← The ZaxNet transceiver will stay in transmit mode and never go into receive mode.

IFB RX PULSE:  
600 SECS

← In this example the ZaxNet transceiver will go out of transmit mode every 10 minutes. You would use this setting if you are monitoring audio via an ERX receiver and you still want the TRX to update time code.

This menu is where you set how often the ZaxNet transceiver will stop sending and search for time code when it is transmitting ZaxNet confidence audio.

When enabled this tells the ZaxNet transceiver to leave ZaxNet transmit mode once every XXX seconds to go into receive mode so it can re-jam its time code wirelessly via ZaxNet. You would use this when you are using ZaxNet on the TRX for confidence monitoring and you still want to update time code at set intervals.

When the ZaxNet transceiver searches for ZaxNet it will temporarily go out of transmit mode for approximately 1 second as it searches for ZaxNet time code.

- The settings are NEVER or any interval between 5 and 999 seconds.

## IFB Record Beep

IFB RECORD BEEP:  
OFF

The IFB record beep is an audible beep that is heard on the ZaxNet confidence audio only.

When the record beep is set to ON, and the TRX is recording, the audio sent to the ERX via ZaxNet will have an audible beep, in 20 second intervals, giving you conformation that the TRX is indeed recording. The beeps will only be heard in the ERX and will not be recorded on the card, or be sent to the receiver.

## Power-Up Mode

POWER UP MODE:  
LOCKED

This menu sets what happens to the keys on the face of the transmitter after boot-up.

- **LOCKED** – After boot-up has completed, the transmitter will automatically go into lock mode and the keys will be locked to prevent accidental changes to the settings.
- **UNLOCKED** – After boot-up the keys will remain unlocked. If you are using this mode you can always lock the keys by going in to the lock screen in the main menu and wait 5 seconds.

To unlock the keys at any time - simultaneously press the MENU and INC keys.

## SD Card Format

*This menu will only appear if a card was inserted prior to booting up*

PRESS UP KEY 5X  
TO ERASE CARD

The Micro SD card is erased and formatted from this menu. Please note that even though many cards are sold preformatted, you must format the card in the TRX prior to any recording. Only cards formatted in the TRX will work properly.

Before formatting the card, you may want to name the transmitter. When you name the transmitter that name is included in the recorded file names. By naming the transmitter it makes it easier to differentiate files from different recorders. So for example you can name the card with the talents name or any other unique identifier. The card name menu is located at the end of the extended menu. The factory default name is the transmitter's serial number.

### Formatting an SD Card:

1. With the power off, insert the memory card into the media slot with the card label to the back of the unit. Press the card all the way in until it "clicks".
2. Power up the transmitter while holding the menu key to enter the extended menu.
3. Press the INC key until this menu appears.
4. Press the INC key 5 times.
5. FORMATTING FAT 32 will be displayed on the screen.
6. After about a minute the TRX will displays "SUCCESS" or "FORMAT FAILED ERROR".
7. If "SUCCESS" appears power cycle the TRX.
8. If the TRX displays "FORMAT FAILED ERROR" try to re-format the card, if it fails again it is not advised to use that card in the transmitter.

## TC Jam Mode Select

TC JAM MODE:  
AUTO-JAM NORMAL

If record run time code is being used this menu controls if the TRX will go into record when it receives a record run time code.

- **AUTO-JAM NORMAL**– The TRX will continuously jam time code via ZaxNet.
- **AUTO-LOAD REC RUN** – The TRX will continuously jam time code via ZaxNet and will start and stop the recording if the unit is receiving record run time code.

In Auto-Load mode the TRX will go into record mode when it detects rolling time code. And will stop when the time code stops. If time code is lost because the IFB signal is too weak the unit will not stop but will continue in whatever state it was in until the time code signal is restored.

## Time Code Source Select

TC SOURCE:  
IFB (RF)

The time code source menu selects how the transmitter will receive its time code.

- **IFB (RF)** – The TRX will receive time code via ZaxNet being broadcast from Nomad, a QRX, IFB100/200, TRX900CL, another TRX transmitter or a ZFR recorder that is transmitting ZaxNet time code.
- **AUDIO INPUT**– The TRX, with a proper cable, will receive time code via the microphone input. When time code is connected, it takes the TRX approximately three seconds to recognize the TC. The screen displays TIME CODE followed by JAM when it is recognized. When the word JAM disappears, the time code input source can be disconnected and normal operation can be resumed. Please note that when using the microphone input connector, the audio level of the time code signal needs to be between -30 and -10 dBFS on the unit's meter. Any level above -10 may cause clipping, which will prevent proper reading of time code.

## Mute Time Code Transmission Until Jammed

MUTE TC UNTIL  
JAMMED: OFF

If the time code menu is set to ON the ZaxNet transmitter will not broadcast time code over ZaxNet until it receives and jams its own internal time code generator. This prevents the ZaxNet from sending incorrect time code to another device.

## IFB Jam Threshold

IFB JAM THRESH  
1000MS (DEFAULT)

This menu sets how much time the time code has to jump before a new file is forcibly created. Please note that when a new file is created, about a half of second of the audio will be lost.

## Group ID Set

REMOTE CONTROL  
GROUP ID = 1

Group ID assigns the TRXLT2 transmitter to a “GROUP” that will be controlled via ZaxNet.

So for example a transmitter set to Group 1 will be controlled by a ZaxNet transmitter set to Group 1 and a group 2 transmitters will be controlled by a Group 2 ZaxNet transmitter. This allows a group of transmitters to be controlled without affecting others. This will also help if two or more people on set are sending ZaxNet commands each person will be independent and won't interfere with each other. Most users leave this set to 1 on all of their Zaxcom products. Group codes can be set from 1 to 99.

## Unit ID Set

REMOTE CONTROL  
UNIT CODE=ALL

The unit code assigns a unique number identify the TRXLT2 within a particular group. This allows individual transmitters in the same group to be independently controlled. So for example if you want to control the gain for each transmitter independently you would set the unit id on each transmitter to a different number. Unit codes can be set to ALL or be assigned any number from 1 to 200.

## Dynamics

### DYNAMICS

The dynamics is a soft knee compressor that is located after the analog to digital converter. The dynamics will limit the dynamic range to prevent clipping during occurrences of loud audio. Dynamics is comprised of both a compressor and an expander, which operate jointly. The compressor in dynamics can set to mild or extreme compression and features a soft knee for more transparent operation.

#### To enter the Dynamics Menu

Press the INC or DEC key - "PARMS" (perimeters) will be displayed on the right.

To move to the next parameter, press the MENU key.

To exit this page, hold the MENU key for 1 second.

#### Dynamics Parameters

- **Link L-R: OFF / ON:** This links the left and right if you are using a stereo recorder. So if one side of the signal needs compressing / expansion the other side will do the same to match.
- **SPEED (Decay Speed) :** SLOWEST / SLOW / NORMAL / FAST / FASTEST  
Sets how gradual the signal level decreases after a signal reaches the threshold setting. This is typically set to FAST.
- **ATTACK (Attack Speed) :** SLOWEST / SLOW / NORMAL / FAST / FASTEST  
Sets the speed in how fast the gain is reduced once the signal exceeds the threshold setting. This is typically set to FAST.
- **CMP RATIO (Compressor Ratio):** Valid range: 1.0: to 5.0:1, in 0.1 steps.  
The amount of gain reduction is determined by the ratio setting.  
A compressor ratio for example of 2.0:1 means for every 1 dB above the compressor threshold the gain will be reduced 2dB. A higher ratio setting makes the compressor more aggressive.
- **CMP THRESH (Compressor Threshold):** Valid range: 0 to -96dB, in 1dB steps.  
This sets the level in which gain reduction occurs.
- **CMP KNEE: (Compressor Soft Knee):** Valid range: 0 to 20dB, In 1dB steps.  
Sets the compressor's soft knee. A soft knee reduces "softens" the audible change from uncompressed to compressed, this is useful especially for higher ratios where the changeover is more noticeable
- **EXP RATIO (Expansion Ratio):** Valid range: 1:1.00 to 1:4.00, In 0.01 steps  
Sets the expansion ratio. For example a 1:2.0 expansion ratio means for every 1 dB below the expansion threshold the gain will be reduced 2dB.
- **EXP THRESH (Expansion Threshold):** Valid range: 0 to -96dB, in 1dB steps.  
Sets the threshold above which gain reduction occurs.
- **REDUCE (Expander Gain Reduction):** Valid range: 0 to -36dB, in 1dB steps.  
This sets the limit on the amount of gain reduction caused by the expander.
- **GAIN (Make-up Gain):** Valid range: 0 to 30dB, In 1dB steps.  
Gain is used to compensate for the gain reduction caused by the compressor. Because the compressor is reducing the gain (or level) of the signal, the ability to add a fixed amount of make-up gain at the output is provided so that an optimum level can be used.



## Battery Type Set

BATTERY TYPE:  
 NIMH QRX

This menu is where the battery type is set. This is so the receiver can properly display the remaining battery capacity. The settings are NIMH, Lithium and Alkaline (Displayed as “ - - - -”). In the menu there is an option for “ENG” and “QRX” – this is so that each Zaxcom receiver model (“ENG” RX900) or (“QRX” QRX) can correctly display the transmitters battery level.

## Recording Mode Set

RECORD MODE:  
LOOP RECORD

Record mode sets what the recorder will do after you reach the file capacity of the card. Regardless of this setting the card will only hold 256 files.

- **NON-LOOP RECORD** (recommended setting) - Once the card has filled up, recording will stop and FULL will be displayed. This prevents over-writing any portion of the audio.
- **LOOP RECORD** - Once the card has filled up, the new audio will begin over-writing the oldest audio on the card.

## Boot Up Power Mode Select

BOOT UP IN  
NORMAL MODE

This menu sets what power mode the transmitter boots up to.

- **NORMAL MODE** – The transmitter will boot up in normally.
- **REMOTE STANDBY** – The transmitter boots up in low power standby mode. The transmitter will be waiting for a ZaxNet “WAKE” command to come up to full power.
- **STANDBY MODE** – The transmitter boots up in low power standby mode. The transmitter will be waiting for you to manually press the MENU key to come up to full power.

## Allow IFB Remote Control

ALLOW IFB REMOTE  
CONTROL: ON

If IFB remote control is set to on the transmitter will accept frequency change commands, remote roll commands and gain changes commands via ZaxNet. If IFB remote control is set to off the transmitter will not receive any ZaxNet commands.

Please note that if the transmitter is transmitting ZaxNet it will not receive remote control commands regardless of this setting.

## QRX Software Update

PRESS  TO SEND  
QRX PROG FILE

This page is used to update the software on a QRX Receiver.

To Update the QRX Software:

1. With a computer copy the QRX software onto a formatted micro SD card.
2. Place the card in the transmitter
3. Power up the transmitter.
4. Advance to this menu.
5. Press the INC key.
6. The transmitter will begin to transmit the software to a QRX Receiver that is set to receive the software. The transmitter will continually resend the program until you manually stop it.

## Transmitter Disable - Record only mode

TX DISABLE:  
NORMAL TX MODE

- **Record Only Mode** – Will set the TRXLA2 to act as a standalone recorder and will not transmit any RF audio on the UHF band and will conserve battery power.
- **Normal TX Mode** – Will allow the TRXLA2 to both transmit RF audio and record on its internal SD card.

## Low Battery Stop Set

LOW BATT STOP:  
NEVER STOP

LOW BATT STOP:  
5 MINUTES

Low battery stop will set the amount of time, after a low battery warning occurs, the on-board recorder will close the current file and stop recording.

This is to prevent possible file corruption if the unit powers off and on due to a dead battery.

- **NEVER STOP** - The onboard recorder will not stop recording unless it is manually stopped by a key press, via ZaxNet or the battery dies.
- **Any interval from 1 to 99 minutes** - once the battery indicator starts blink a low battery warning the onboard recorder will continue to record for the time set here - then it will close the file and stop recording.

## Automatic Record after Boot up



RECORD ON BOOTUP  
ON

Record after boot-up allows the onboard recorder to automatically go into record after the transmitter boots up.

- **ON** - The onboard recorder will automatically start to record after it boots up.
- **OFF** - The onboard recorder will wait for a ZaxNet command or a manual record trigger to start recording.

## Transmitter Name Set

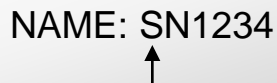

NAME: SN1234  
↑

The transmitter name menu allows the transmitter to be named to be changed from the transmitter the default name - which is the unit's serial number. The name entered becomes part of the name of the recorded audio files, and is also included in the metadata of the BWF file. Naming the unit aids in identifying the files from several different wireless.

The maximum name length is 8 characters. Any letter or number can be used. If desired a space can even be used.

To set/change the transmitter name:

1. Press the INC or DEC key to change the character in the current position.
2. Press the MENU key to proceed to the next character.
3. When finished, press and hold the MENU key to set the name or you can cycle the power.

## Hide Encryption Menu



ENCRYPTION MENU:  
HIDDEN

This menu allows for the encryption menu to be hidden preventing accidental changes.

- **HIDDEN** the encryption menu doesn't appear when you cycle through the menu settings.
- **ON** the encryption menu will appear.

## Encryption Code Set



ID1:000 ID0:000  
↑

If an encryption code is set the transmitted audio will be encrypted and can only be listened to if the receiver has the matching encryption code entered. When receiving an audio signal and the codes do not match, all that will be heard is white-noise or silence. So if using encryption it is important to make sure the matching receiver has the same code.

These two sets of numbers are formed into a single six-digit encryption code which provides a total of 16,777,216 possible combinations.

Please note that both of these codes should be set to 000 for normal un-encrypted operations

### Adjusting the encryption code

1. Momentarily press the MENU key to advance to the next character.
2. To change the designated character, press the INC or DEC key.
3. To exit this page, press and hold the MENU key for 1 second.

## Media

While any size card will work we recommend using a 4GB Micro SD card. We also recommend that you buy a brand name card such as Transcend, SanDisk. You should always buy your cards from a reputable dealer because counterfeit cards exist and can cause recording issues.

We also recommend that you test your card before taking them out into the field.

Here is a testing procedure to determine if the card will function correctly:

1. Format the card in the transmitter.
2. Power cycle the unit.
3. Record at least 20 minutes of audio to a card with no time code source.
4. Look at the Main Screen it should still be recording in segment #1.

## Media Capacity

The TRX can use Micro SD cards, ranging in size from 128 MB to 16 GB. While any size card will work we recommend using 4GB cards.

Please note that regardless of the size of the card the onboard recorder will only be able to record up to 254 individual segments on any given card.

Available recording times are as follows:

Media Size	Available Recording Time
128 MB	45 minutes
256 MB	1.5 hours
512 MB	3 hours
1 GB	6 hours
2 GB	12 hours
4 GB	24 hours
8 GB	48 hours
16 GB	96 hours

Please note the transmitter will **NOT** record onto the card if:

- The card was not inserted when the ZFR was powered up.
- If the card was removed while the power was 'ON'.
- If the LOW BATTERY is being displayed.

## Recording Format

The media card is formatted using a FAT32 file system. While recording, the unit places all recorded audio in a single file on the media.

The files generated by the recorder (.zax format) can only be recognized by Zaxcom's ZaxConvert program.

Using ZaxConvert will transfer the file to a Broadcast Wave or MP3 file. This utility is available to anyone for free from the Zaxcom website <http://www.zaxcom.com/software-updates>

## Firmware

Each unit is shipped with the latest firmware version installed. As newer firmware becomes available, it can be downloaded from the Zaxcom website:

<http://www.zaxcom.com/software-updates>

Newer version of Beta software may be found on the Zaxcom Forums:

<http://www.zaxcom.com/forum>

Each time a unit is powered up, the firmware version number is displayed briefly on the LCD screen. Pressing the DEC key during the boot up will slow down the screen to allow easier viewing of the information.

## Updating TRX Firmware

1. Download the new firmware from the Zaxcom website and load it onto a formatted card.
2. Insert the card into the TRX transmitter.
3. Simultaneously hold down the INC and DEC keys while powering up the unit.
4. The screen will display "BURN ROM" with the version of firmware you are loading.
5. From power up to "DONE" will take about 30 seconds.
6. Upon completion, cycle the power to run on the new version.

**WARNING:** Do not power down the unit during the update process, and before updating the software be sure to insert a fresh set of batteries. If the unit should lose power during the upgrade, it will need to be sent back to Zaxcom for repair.

## Updating an ERX with a TRX Transmitter

1. Format a card in TRX transmitter.
2. With a computer perform the following:
  - Delete the “DELETE.ME” file on the card
  - Download the ERX firmware “ERX-XXX.bin” from the Zaxcom website and load it onto a card formatted by the TRX.
3. Insert the card into the TRX.
4. Check that the ERX is set to the same ZaxNet frequency that the TRX is set to. Check that the GROUP ID is set the same in both the TRX and ERX. And make sure encryption is shut off.
5. Boot up the ERX while holding the Menu key to get to the ERX EXTENDED menu.
6. On the ERX Press menu 5 times till you see the software update page.
7. Press the INC key on the ERX 5 times till you see WAITING FOR PROGRAM.
8. Power up the TRX.
9. If your TRX is running software version 8.0 or higher in the EXTENDED Menu shut off RX to TX mode.
10. Go to the LOCK page in the main menu and press down 6 times quickly to get to the FACTORY Menu.
11. Press the MENU key once to get to the IFBMODE page.
12. Press the INC key 3 times till you see IFBMODE 3 TX.
13. Press MENU 3 times until you see SEND ERX PROG FILE.
14. Press the INC key to trigger the update process.
15. The ERX should indicate its progress after a few seconds.
16. When the ERX has been updated the screen will display “SUCCESS”.

**WARNING:** Do not power down the unit during the update process, and before updating the software be sure to insert a fresh set of batteries. If the unit should lose power during the upgrade, it will need to be sent back to Zaxcom for repair.

## Inputting Audio

The TRXLT2 use an unbalanced microphone input via a 3-pin micro-LEMO connector. You can use an unbalanced dynamic microphone or a powered lavalier.

You can use a line-level input though an inline pad is required.

## Recommended Microphones

Zaxcom recommends the following microphones for use with the TRXLA2:

Countryman EMW, B3, B6, Sanken COS-11D, DPA 4063

## Wiring Diagrams

The following 3-pin micro-LEMO connectors mate with the microphone connector:

- FGB.00.303.CLAD.22 – has a latch with a pull release.
- FVB.00.303.NLA – has a latch with a twist release.

Please note it is recommended that the ground gets attached to the shell of the LEMO connector.

### Two Wire Microphone Configuration

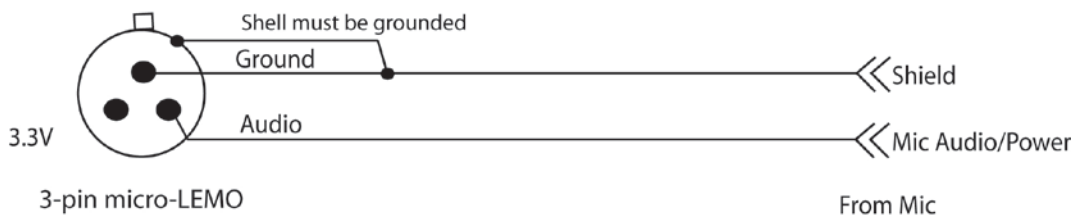

### Three Wire Microphone Configuration

*Please contact your microphone manufacturer.*



### Stereo Microphone Configuration – for TRXLT2S

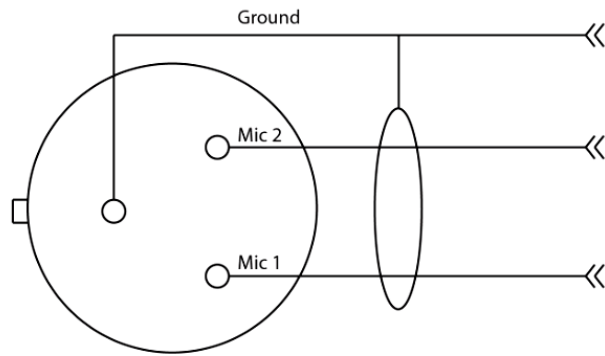

### Balanced Line Level and time code Input

Mono line-level and/or timecode input

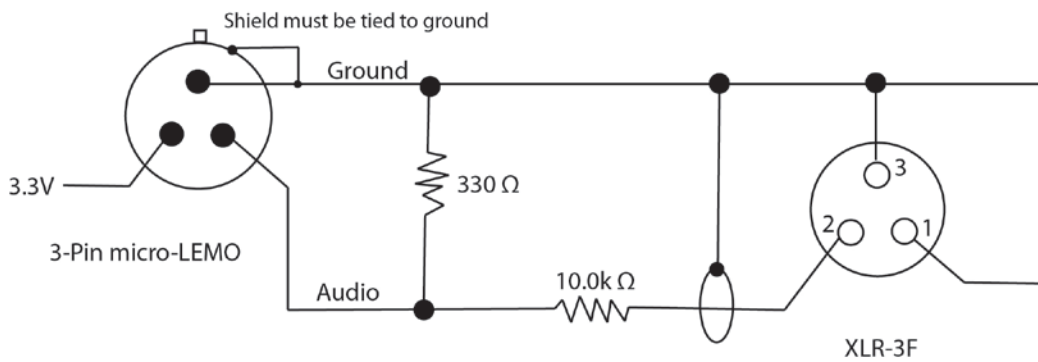

### Stereo Line Level

Stereo line-level input with pads

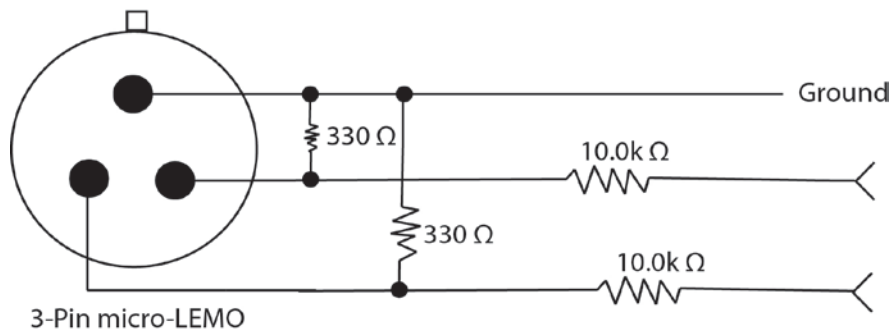

For use with TRX900LTS, TRX900LTHS, TRX900LAS, ZFR200S & ZFR300S

## Operating Frequencies

### ZaxNet Remote Control and Time Code

2.403 to 2.475 GHz

### UHF Audio

TRXLT2.5

512.0 MHz to 614.0 MHz (Blocks 20 through 23)

TRXLT2.6

596.0 MHz to 698.0 MHz (Blocks 23 through 26)

# SMA/SSMA ANTENNA CUTTING CHART

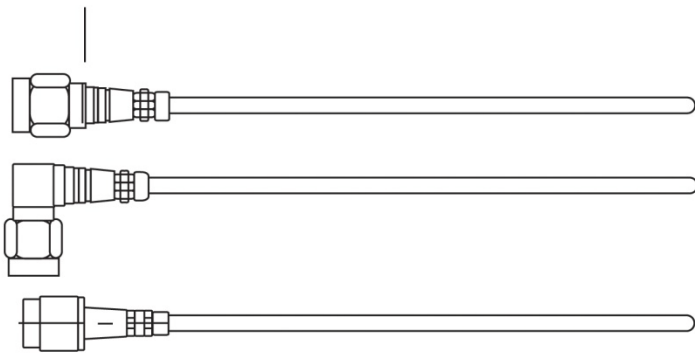
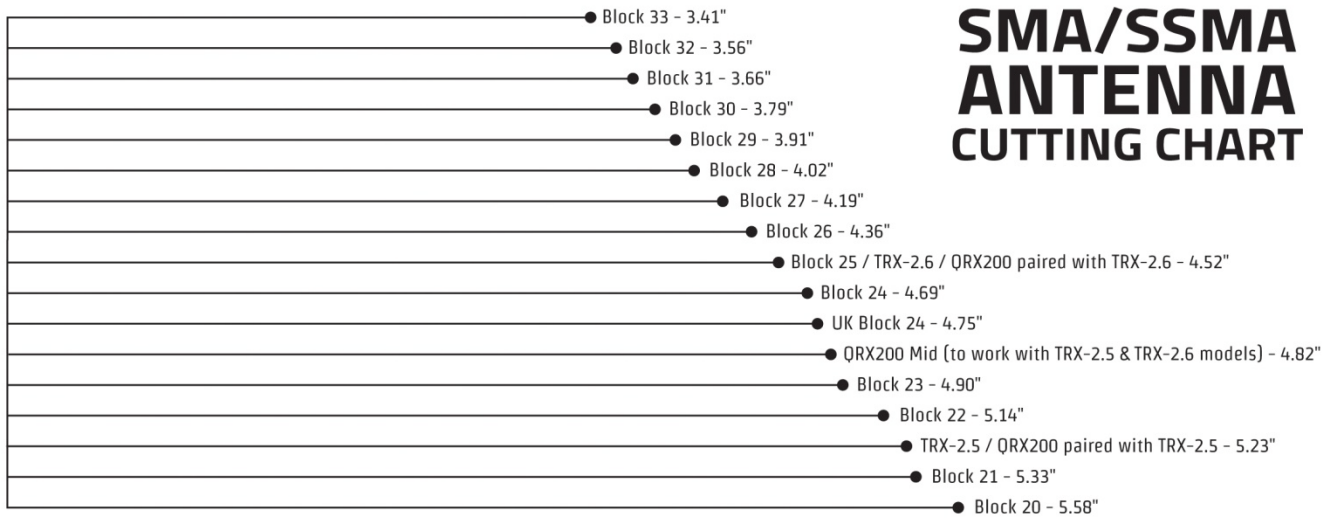

**ZAXCOM**  
www.zaxcom.com



## Product Support

- Register** your product with Zaxcom: <http://zaxcom.com/support/product-registration/>
- Download the latest **Firmware** from: <http://zaxcom.com/support/updates/>
- Download the latest **User Manuals** from: <http://zaxcom.com/support/updates/>
- Submit Technical Questions** at: <http://www.zaxcom.com/submit-a-technical-question>
- Submit information for **Repair Services** at: <http://www.zaxcom.com/support/repairs>
- Join the **Zaxcom User Forum** at: <http://www.zaxcom.com/forum/forum.php>
- Join the **Zaxcom Face Book User Group** at: <https://www.facebook.com/groups/682199065139938/>

## Specifications

### Transmitter

Power output: 50 mW  
RF Modulation: Proprietary Digital Method  
RF Frequency Range: TRXLA2.5: 512 - 614 MHz  
TRXLA2.6: 596 -698MHz  
RF Frequency Step: 100 KHz  
RF Bandwidth: 200 KHz  
Channel Separation: 500 KHz (700 KHz recommended)  
Antenna Connector: 50  $\Omega$  SMA Female  
Emission Designator: 180 KV2E  
FCC Part: 75.861

### Transmitter Audio

A-D Dynamic Range: 127dB  
Analog distortion: 0.002%  
A-D system: NeverClip Zaxcom proprietary (Pat Pending)  
Frequency Response: Mode 0: 20 Hz to 16 kHz / T & M Mode 0.2 Hz to 16 kHz  
System Group Delay: 3.5 mS  
Mic Power: 3.3VDC  
Mic Connector: 3-Pin Micro LEMO  
Mic impedance: 6.8 k  $\Omega$   
ADC Bit-Depth: 24 Bits  
ADC Sampling Rate: 48kHz

### Time code Reader/Generator

Clock Accuracy: 1.54PPM (1 Frame Out in 6 Hours)  
Timecode Type: SMPTE  
Timecode Frame Rates: 23.98, 24, 25, 29.97NDF, 29.97DF, 30NDF, 30DF

### Recording

Media: Micro SD Card (Flash Memory)  
File Format: .ZAX  
Recording Time: 96 Hours (16 GB card)

### 2.4 GHz ZaxNet Receiver

RF Frequency Range: 2.403 to 2.475 GHz  
RF Modulation: Digital Spread Spectrum  
RF Frequency Step: 0.001 GHz (1 MHz)  
RF Bandwidth: 1 MHz  
Channel Separation: 2 MHz  
Sensitivity: -96 dBm

### Physical

Weight: 3.1 oz with battery  
Dimensions (H x W x D): 2.4" X 2.4" X .65"  
Display: Graphic LCD

*All Specifications are subject to change without notice.*

# Zaxcom Warranty Policy and Limitations

Zaxcom Inc. values your business and always attempts to provide you with the very best service.

No limited warranty is provided by Zaxcom unless your TRX ("Product") was purchased from an authorized distributor or authorized reseller. Distributors may sell Product to resellers who then sell Product to end users. Please see below for warranty information or obtaining service. No warranty service is provided unless the Product is returned to Zaxcom Inc. or a Zaxcom dealer in the region where the Product was first shipped by Zaxcom.

## Warranty Policy

The Product carries a Standard Warranty Period of one (1) year.

**NOTE:** The warranty period commences from the date of delivery from the Zaxcom dealer or reseller to the end user.

There are no warranties which extend beyond the face of the Zaxcom limited warranty. Zaxcom disclaims all other warranties, express or implied, regarding the Product, including any implied warranties of merchantability, fitness for a particular purpose or non-infringement. In the United States, some laws do not allow the exclusion of the implied warranties.

## Troubleshooting & Repair Services

No Product should be returned to Zaxcom without first going through some basic troubleshooting steps with the dealer you purchased your gear from.

To return a product for repair service, go to the Zaxcom Repair Services page <http://www.zaxcom.com/repairs> and fill in your information; there is no need to call the factory for an RMA. Then send your item(s) securely packed (in the original packaging or a suitable substitute) to the address that was returned on the Repair Services page. Insure the package, as we cannot be held responsible for what the shipper does.

Zaxcom will return the warranty repaired item(s) via two-day delivery within the United States at their discretion. If overnight service is required, a FedEx or UPS account number must be provided to Zaxcom to cover the shipping charges.

\*Please note a great resource to troubleshoot your gear is the Zaxcom Forum: <http://www.zaxcom.com/forum>.

## Warranty Limitations

Zaxcom's limited warranty provides that, subject to the following limitations, each Product will be free from defects in material and workmanship and will conform to Zaxcom's specification for the particular Product.

### Limitation of Remedies

Your exclusive remedy for any defective Product is limited to the repair or replacement of the defective Product.

Zaxcom may elect which remedy or combination of remedies to provide in its sole discretion. Zaxcom shall have a reasonable time after determining that a defective Product exists to repair or replace a defective Product. Zaxcom's replacement Product under its limited warranty will be manufactured from new and serviceable used parts. Zaxcom's warranty applies to repaired or replaced Product for the balance of the applicable period of the original warranty or thirty days from the date of shipment of a repaired or replaced Product, whichever is longer.

### Limitation of Damages

Zaxcom's entire liability for any defective Product shall, in no event, exceed the purchase price for the defective Product. This limitation applies even if Zaxcom cannot or does not repair or replace any defective Product and your exclusive remedy fails of its essential purpose.

### No Consequential or Other Damages

Zaxcom has no liability for general, consequential, incidental or special damages. These include loss of recorded data, the cost of recovery of lost data, lost profits and the cost of the installation or removal of any Product, the installation of replacement Product, and any inspection, testing or redesign caused by any defect or by the repair or replacement of Product arising from a defect in any Product.

In the United States, some states do not allow exclusion or limitation of incidental or consequential damages, so the limitations above may not apply to you. This warranty gives you specific legal rights and you may also have other rights, which vary from state to state.

### Your Use of the Product

Zaxcom will have no liability for any Product returned if Zaxcom determines that:

- The Product was stolen.
- The asserted defect:
  - Is not present,
  - Cannot reasonably be fixed because of damage occurring when the Product is in the possession of someone other than Zaxcom, or
  - Is attributable to misuse, improper installation, alteration, including removing or obliterating labels and opening or removing external covers (unless authorized to do so by Zaxcom or an authorized Service Center), accident or mishandling while in the possession of someone other than Zaxcom.
- The Product was not sold to you as new.

### Additional Limitations on Warranty

Zaxcom's warranty does not cover Product, which has been received improperly packaged, altered or physically abused.

## NOTICE:

Most users do not need a license to operate a wireless microphone system. Nevertheless, operating a microphone system without a license is subject to certain restrictions:

- the system may not cause harmful interference,
- it must operate at a low power level (not in excess of 50 mill watts),
- it has no protection from interference received from any other device.

Purchasers should also be aware that the FCC is currently evaluating the use of wireless microphone systems, and these rules are subject to change. For more information, call the FCC at 1-888-CALL-FCC (TTY: 1-888-TELL-FCC) or visit the FCC's wireless microphone website at: [www.fcc.gov/cgb/wirelessmicrophones](http://www.fcc.gov/cgb/wirelessmicrophones). To operate wireless microphone systems transmitting with greater than 50mW of radiated power, you must qualify as a Part 74 user and be licensed.

This alert does **NOT** apply to Part 74 users

Warning: Changes or modifications to this device not expressly approved by Zaxcom Inc. could void the user's authority to operate the equipment.

NOTE: This equipment has been tested and found to comply with the limits for a Class B digital device, pursuant to Part 15 of the FCC Rules. These limits are designed to provide reasonable protection against harmful interference in a residential installation. This equipment generates, uses, and can radiate radio frequency energy and, if not installed and used in accordance with the instructions, may cause harmful interference to radio communications. However, there is no guarantee that interference will not occur in a particular installation. If this equipment does cause harmful interference to radio or television reception, which can be determined by turning the equipment off and on, the user is encouraged to try to correct the interference by one or more of the following measures:

- Reorient or relocate the receiving antenna.
- Increase the separation between the equipment and receiver.
- Connect the equipment into an outlet on a circuit different from that to which the receiver is connected.
- Consult the dealer or an experienced radio/TV technician for help.

### RF Exposure:

This equipment complies with FCC radiation exposure limits set forth for an uncontrolled environment. This equipment is in direct contact with the body of the user under normal operating conditions. This transmitter must not be co-located or operating in conjunction with any other antenna or transmitter.

Under Industry Canada regulations, this radio transmitter may only operate using an antenna of a type and maximum (or lesser) gain approved for the transmitter by Industry Canada. To reduce potential radio interference to other users, the antenna type and its gain should be so chosen that the equivalent isotropically radiated power (e.i.r.p.) is not more than that necessary for successful communication.

Conformément à la réglementation d'Industrie Canada, le présent émetteur radio peut fonctionner avec une antenne d'un type et d'un gain maximal (ou inférieur) approuvé pour l'émetteur par Industrie Canada. Dans le but de réduire les risques de brouillage radioélectrique à l'intention des autres utilisateurs, il faut choisir le type d'antenne et son gain de sorte que la puissance isotrope rayonnée équivalente (p.i.r.e.) ne dépasse pas l'intensité nécessaire à l'établissement d'une communication satisfaisante.

This radio transmitter (contains the module PR6-XRT) and has been approved by Industry Canada to operate with the antenna types listed below with the maximum permissible gain and required antenna impedance for each antenna type indicated. Antenna types not included in this list, having a gain greater than the maximum gain indicated for that type, are strictly prohibited for use with this device.

Quarter Wave Whip Antenna, 5.19dBi gain, 50 Ohms

Le présent émetteur radio (PR6-XRT) a été approuvé par Industrie Canada pour fonctionner avec les types d'antenne énumérés ci-dessous et ayant un gain admissible maximal et l'impédance requise pour chaque type d'antenne. Les types d'antenne non inclus dans cette liste, ou dont le gain est supérieur au gain maximal indiqué, sont strictement interdits pour l'exploitation de l'émetteur.

Quarter Wave Whip Antenna, 5.19dBi gain, 50 Ohms

USA - FCC Part 74, FCC Identifier PR6XRT

Canada - Industry Canada RSS 210, IC:12755A-XRT

Zaxcom Digital Wireless are protected under following patent #'s:  
4,327,066 / 7,711,443 / 7,929,902 / 8,385,814 / 8,878,708 / 8,842,854



## Declaration of Conformity

ZAXCOM, INC.  
230 West Parkway, Unit 9  
Pompton Plains, NJ 07444  
September 1, 2015

We certify and declare under our sole responsibility that the following product:

TRXLA2, TRXLT2, TRX742 and TRX900CL wireless microphone transmitters  
Restrictive use for residential, office and professional use only

Conforms with the essential requirements of the EMC Directive 2004/108/EC and  
R&TTE Directive 99/5/EC, based on the following specifications applied:

EN 300 422-2 v1.3.1 Radio Parameters  
EN 301 489-9 v1.4.1 Immunity  
EN 60950: 2006/A1:2011 Product Safety (low voltage directive)  
EN 50566: 2013 RF Exposure Safety

Our authorized representative in Europe is Mr. Roger Patel, Director of Everything  
Audio located at Elstree Film Studios, Shenley Road, Borehamwood, Herts WD61JG in  
England.

Glenn Sanders  
President  
Zaxcom, Inc.

Zaxcom, Inc.  
230 West Prkwy, Unit 9  
Pompton Plains, NJ  
07444 USA

zaxcom.com  
973.835.5000 (tel)  
973.835.6633 (fax)



